

Product highlights:

1. Integrated design, quick disassembly structure and convenient installation
2. 30x continuous optical zoom
3. High precision laser ranging, target positioning, unparalleled
4. With AI passenger car recognition function
5. 360 ° infinite cyclic rotation
6. Small size, light weight and low power consumption

Dimensions

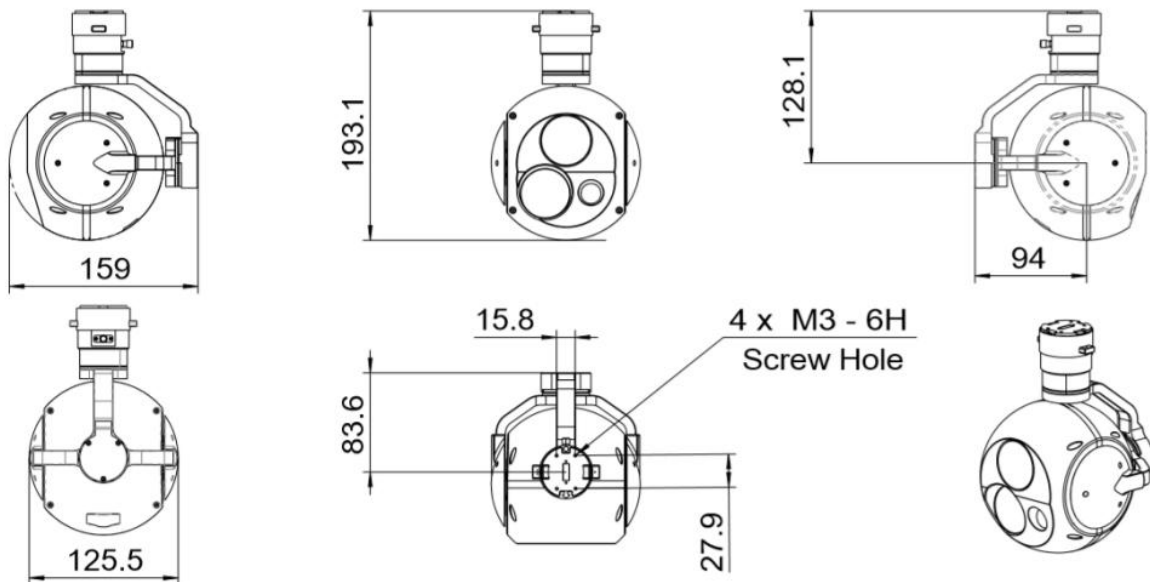

Parameters

MODEL		F2IV-30
System specification	System type	Gyro stability
	Weight	970g
Stable system	Platform type	Tri-axis
	Azimuth	360° rotation
	pitch	-100° ~+100°
	Maximum search angular velocity	$\geq 100^\circ /s$
	Stability accuracy	0.1mrad(1° /2HZ)
	Angular position accuracy	$\leq 0.3^\circ$
Visible light camera 1	Resolution and frame rate	SONY7520 1920×1080 @60fps
	FOV	63° × 35° ~2.3° × 1.3°
Visible light camera 2	Resolution and frame rate	1920×1080 @60fps
	FOV	38.4°×22.2°(8mm prime lens)
Infrared camera	Resolution and frame rate	640×480@60fps
	SMALL FOV	12.5° ×9.4° (35mm prime lens)
Tracking module	Frame rate	60Hz
	Tracking speed	± 48 Pixel/frame
System external interface	Control	RS232、NET
	Video output	NET、SDI
Power supply	Power	12~28V
	Power consumption	$A_v \leq 15W$, $Max \leq 30W$
Environmental conditions	Operating temperature	-10°C ~+50°C
	Storage temperature	-40°C ~+60°C